

CARTRIDGE DISC SYSTEM
FOR NORD-10

Programming Specifications

A/S NORSK DATA-ELEKTRONIKK

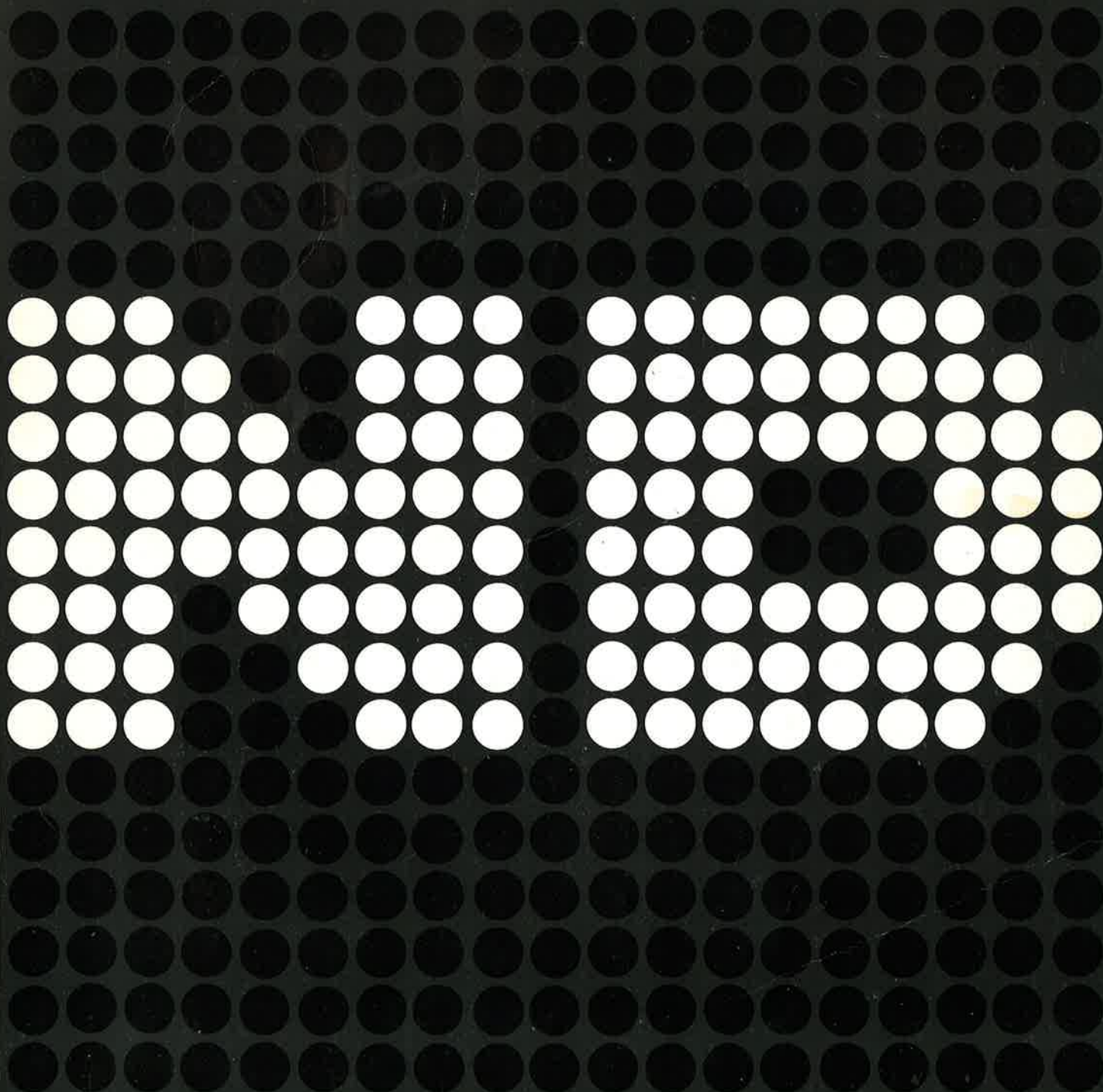



**CARTRIDGE DISC SYSTEM
FOR NORD-10**

Programming Specifications



REVISION RECORD

Revision	Notes
12/73	Original Printing
10/76	The following pages are revised:
Rev. A	1-1, 2-1, 5-5, 5-6, 6.1

Publ. No. ND-11.008.01
December 1973



TABLE OF CONTENTS

+++
+

<u>Chapters:</u>		Page
1	SYSTEM ORGANIZATION	1-1
2	DISC SPECIFICATIONS	2-1
2.1	Data Format	2-1
2.2	Capacity	2-1
2.3	Access Time	2-1
2.4	Transfer Rate	2-1
2.5	Power Requirement	2-1
2.6	Environment	2-2
3	DISC ADDRESSING	3-1
3.1	Disc Address Format	3-1
4	PREPARING FOR A TRANSFER	4-1
5	DISC DEVICE REGISTER ADDRESSES	5-1
5.1	Load Register Instructions	5-1
5.1.1	Load Core Address Register (CAR)	5-1
5.1.2	Load Block Address Register (BAR)	5-1
5.1.3	Load Control Word (CW)	5-1
5.1.4	Load Word Count Register (WC)	5-4
5.2	Read Register Instructions	5-4
5.2.1	Read Core Address Register (CAR)	5-4
5.2.2	Read Sector Counter (SECT)	5-5
5.2.3	Read Status Register (STR)	5-5
5.3	Seek Instruction	5-7
5.4	Data Transfer	5-7
5.4.1	Starting a Transfer	5-7
5.4.2	Completion of a Transfer	5-7
5.4.3	Interrupt	5-8
6	WRITE PROTECT	6-1

--ooOoo--

1 SYSTEM ORGANIZATION

Four disc units (CDC 9427) each having two discpacks may be connected to the NORD-10 COMPUTER via a disc controller. The disc controller contains the logic that interprets the NORD COMPUTER function codes, controls the Cartridge Disc Drive operations, assembles and disassembles 16 bit words between the computer and the disc drive and provides status information to the computer.

Each discpack has a capacity of approx. 2.5 mill. 16 bit words. Data is transferred in blocks of from 128 to 3072 words directly between disc and core memory. Transfers are started by means of IOX instructions, specifying transfer mode and actual core and disc addresses.

2 DISC SPECIFICATION

2.1 Data Format

Word format: 16 data bits per word
 Sector format: 128 data words per sector followed by a 16 bit cyclic redundancy check word.

2.2 Capacity

Capacity per sector: 128 words
 Capacity per track: 3072 words
 Capacity per cylinder: 12288 words
 Capacity per discpack: **2506752 words**
 Capacity per unit: **5013504 words**

2.3 Access Time

Access time is defined as the sum of the cylinder positioning time and latency time.

Maximum positioning time: 70 ms
 Cylinder to Cylinder positioning time: 7 ms
 Average positioning time: 35 ms
 Maximum latency (1 revolution): 25,5 ms
 Average latency ($\frac{1}{2}$ revolution): 12,5 ms
 Max access (max. pos + max. latency): 95,5 ms
 Average access (av. pos + av. latency): 47,5 ms

2.4 Transfer Rate

Bits: 2,5 MHz = 400 ns/bit
 Words: 156 KHz = 6,4 μ s/word
 Sectors: = 1,06 ms/sector

2.5 Power Requirement

Voltage: 220V AC \pm 10%
 49 - 50,5 Hz
 Current: 3,5A
 Power: 600 watt

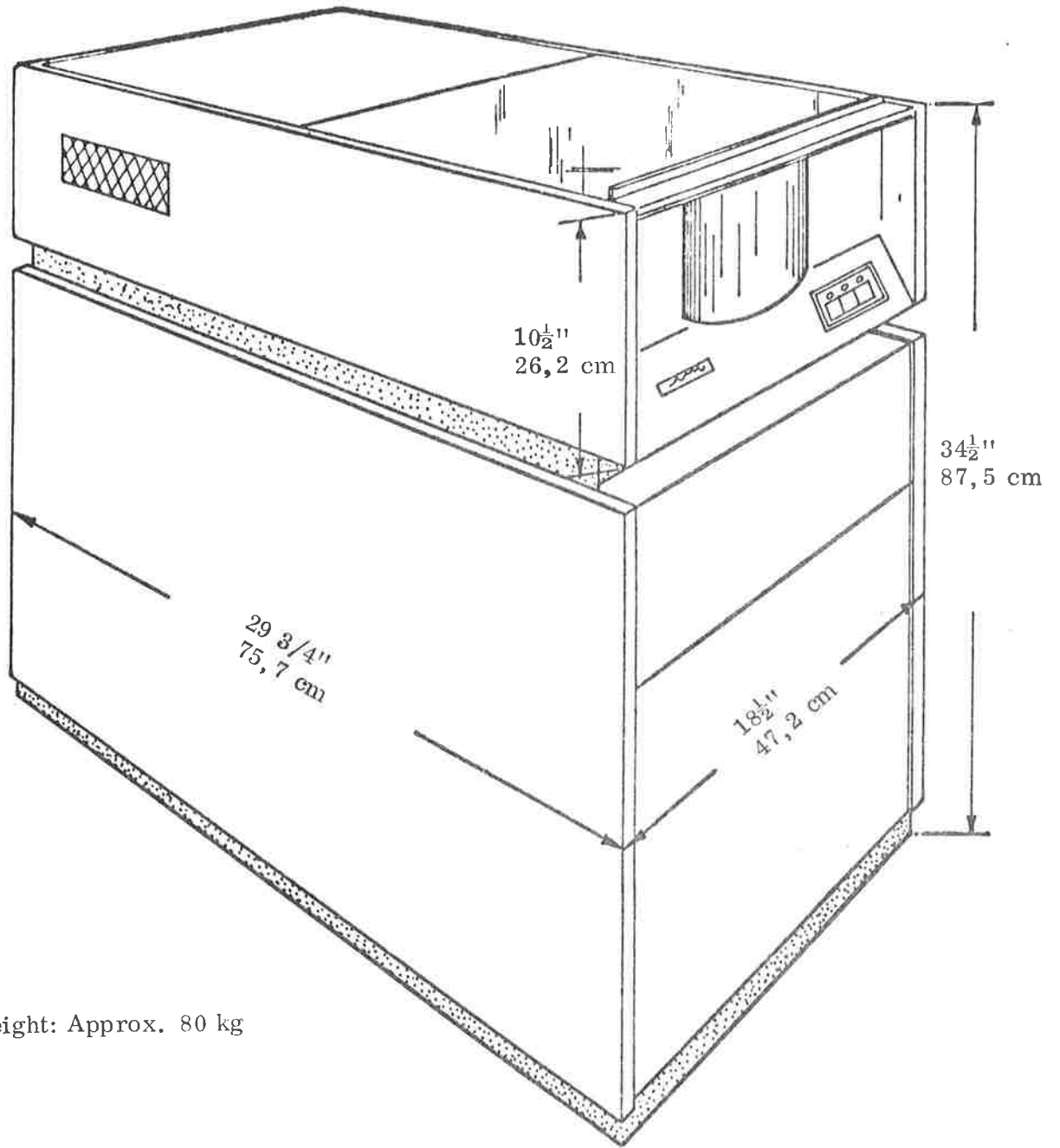

Weight: Approx. 80 kg

Figure 1 Physical characteristics:
Cartridge disc drive with cabinet.

2.6 Environment

Operating temperature range: 16 - 30°C
 Relative humidity: 10 - 80% no condensation

Shock

The equipment shall not suffer damage or fail to perform as specified herein when subjected to 18 impact shocks of 5 ± 0.5 G consisting of 3 shocks in opposite directions along each of 3 mutually perpendicular axis. Each shock impulse shall have a time duration of 11 ± 1 ms. The maximum g shall occur at approx. 5.5 ms.

Vibration

The equipment shall not suffer damage or fail to perform as specified herein when subjected to the following vibration levels:

<u>Frequency (Hz)</u>	<u>Level</u>
5 - 12.5	0.05 g
12.5 - 18	0.006 inch double amplitude
18 - 30	0.10 g
30 - 50	0.002 inch double amplitude
50 - 500	0.25 g

Error RateWrite Recoverable Errors.

Definition - A recoverable write error is one which may be corrected by three or less attempts to write the record.

Error Rate - For data written on the disc the recoverable write error rate shall be less than one error in 10^{10} bits, provided a header check is made prior to each write operation.

Read Recoverable Errors

Definition - A recoverable read error is one which may be corrected by three or less attempts to read the record.

Error Rate - For data that has been verified as being written errorfree, the recoverable read error rate for any subsequent read operation shall be less than one error in 10^{10} bits.

Write Irrecoverable Errors

Definition - An irrecoverable write error is one which cannot be corrected after three attempts at writing the record.

Error Rate - Irrecoverable write errors shall be considered as failures affecting mean time between failure (MTBF).

Read Irrecoverable Errors

Definition - An irrecoverable read error is one which cannot be recovered after three attempts to read the record, providing the previous write operation has been verified.

Error Rate - Irrecoverable read errors shall be considered as failures affecting MTBF.

3 DISC ADDRESSING

Each disc cartridge consists of a single disc unit providing two surfaces for data recording. Each surface has one read/write head. The head assembly consisting of four read/write heads can be moved to 408 different positions called "cylinders", see fig. 2. The path formed by one head during one revolution is called a "track". Each surface is divided into 24 sectors. The part of a track lying within a sector is called a "block". A unique "block address" is assigned to each block.

3.1 Disc Address Format

Each block in the disc file is assigned a sixteen bit block address. The block address is divided into four parts:

- Bits 0 - 4: designate the sector within the track (1 of 30₈)
- Bit 5: the surface of a disc (upper or lower surface)
- Bits 6 - 14: designate the cylinder within a disc (1 of 408₁₀)
- Bit 15: designates the fixed or removable disc

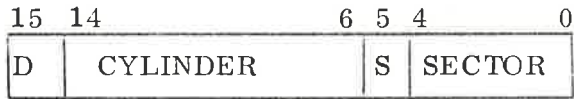

- S - surface
 - S = 0 i.e. upper surface
 - S = 1 i.e. lower surface
- D - disc
 - D = 0 i.e. removable cartridge
 - D = 1 i.e. fixed disc

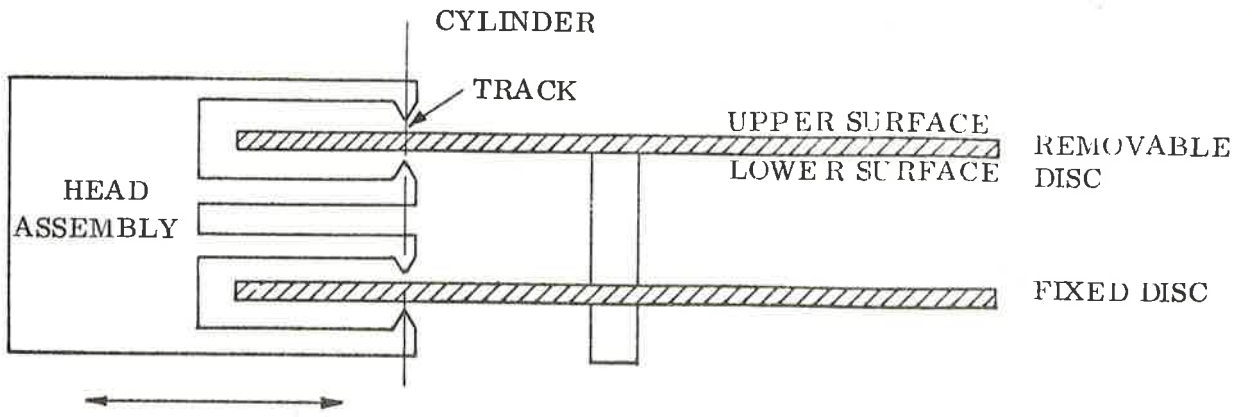

Figure 2 · DISC ASSEMBLY

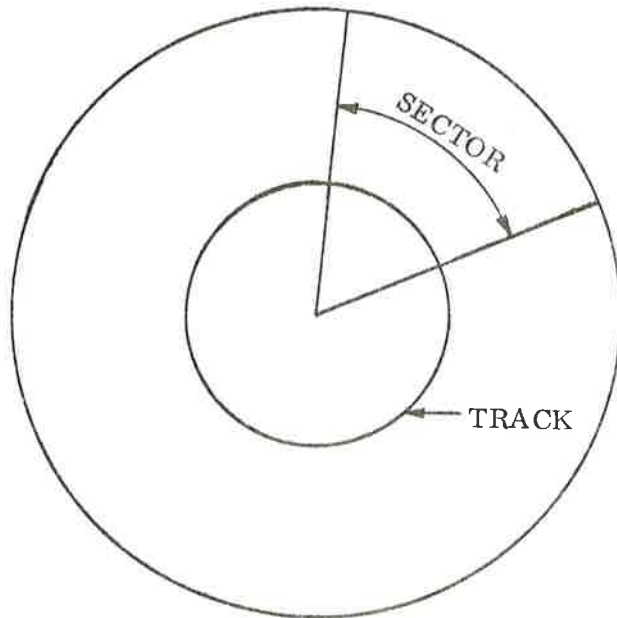

Figure 3 · SECTOR AND TRACK DEFINITION

4

PREPARING FOR A TRANSFER

Before a transfer can be called, IOX instructions, to be described in the next section, are used to load and read certain registers in the disc controller.

- a) Load the "core address register" (CAR) with the first core address to or from which the transfer is to be directed.
- b) Load the "block address register" (BAR) with the actual block address, see section 3.1 for address format.
- c) Load the "control register" (CW) with the unit code of the desired disc unit.
- d) Load the "word count register" (WCR) with the number of words to be transferred.
- e) Read "status register" (STR) to check that the selected disc unit is ON CYLINDER.

(Note that this indication is necessary only to show that the heads are at rest at any cylinder, not necessarily the cylinder from where the next transfer is taken.)

The transfer may now be performed by executing the "IOX Load CW" with bit 2. activate device. and the correct unit code and device operation set.

5 DISC DEVICE REGISTER ADDRESSES

The codes below are relevant for disc system I. Each disc system may consist of 4 disc units. For disc system II add 10_8 to the specified codes. The following codes are used:

Read Core Address:	IOX	500
Load Core Address:	IOX	501
Read Sector Counter:	IOX	502
Load Block Address:	IOX	503
Read Status Register:	IOX	504
Load Control Word:	IOX	505
Seek Instruction:	IOX	506
Load Word Count Register:	IOX	507
Read Block Address Register		

Load the control word with bit 3 (Test Mode) set. IOX 506 will then return the previously loaded block address to the A-register.

5.1 Load Register Instructions

5.1.1 Load Core Address Register (CAR)

IOX 501 % (A) \longrightarrow CAR

5.1.2 Load Block Address Register (BAR)

IOX 503 % (A) \longrightarrow BAR

See Section 3.1 for block address format.

5.1.3 Load Control Word (CW)

IOX 505 % (A) \longrightarrow CW

The control word gives the controller the necessary information of the functions to be performed. The control word contains the following code:

Bit	0	Enable interrupt on device ready for transfer
	1	Enable interrupt on errors
	2	Activate device
	3	Test mode
	4	Device clear
	5	Address bit 16
	6	Address bit 17
	7 - 8	Not assigned
	9	Unit select
	10	Unit select
	11	Device operation
	12	Device operation
	13 - 14	Not assigned
	15	Write format

Bit 3: Test Mode

This bit is included for maintenance only. Most of the disc controller may be checked out without a physical disc unit connected when this bit is specified. The IOX instructions have to be performed as usual. When a Read Transfer together with Test is specified, pre-wired data words are transferred to the core memory. The contents of the data words are:

Even words:	125252
Odd words:	052525

In order to get a transfer successfully during test, the block address register has to be specified with the content 125252.

Bit 9-10: Unit Select

These bits select one of four disc drive units. Functionally this is only an extension of the disc address. The control word bits 9 and 10 are thus decoded:

Bit 10	9	
0	0	Unit 0 selected
0	1	Unit 1 selected
1	0	Unit 2 selected
1	1	Unit 3 selected

Bit 11-12: Device Operation Code

Bit 12	11	
0	0	Read transfer
0	1	Write transfer
1	0	Read parity
1	1	Compare test

Read Transfer

This mode causes the controller to transfer data from the disc to the computer memory.

Write Transfer

This mode causes the controller to transfer data from the computer memory to the disc.

Read Parity

This mode causes the controller to check the data previously written on the disc for parity errors. The data is transferred to the controller and the cyclic check word read from a sector is compared with the correct check word, generated by the controller. Mismatch causes the parity error bit (status bit no. 9) to be set. No data transfer to or from the computer is performed.

Compare Test

This function is included to positively check the data just written on the disc. During compare test the controller compares contents from the disc and the computer memory on a bit by bit base. Mismatch causes the compare error bit (status bit no. 10) to be set.

Bit 15: Write Format

This function in conjunction with the FORMAT ON key switched on in the disc and a WRITE TRANSFER, causes the controller to write the address tags of all the sectors in the track. The 30₈ consecutive sector tags on a track have to be placed in core with a format as defined in Section 3.1. The word count register has to be set to 30₈

5.1.4 Load Word Count Register (WC)

IOX 507 % (A) → WC

The minimum number of words to be transferred in one call is one sector, i. e. 200₈ words, the maximum number of words is one track, i. e. 24₈ sectors or 6000₈ words.

The blocks will be transferred in the order they evolve during the disc rotation. Thus a transfer starting with block address 26₈ with a word count of 1200₈ will effectively transfer the following block sequence: 26 - 27 - 0 - 1 - 2.

5.2 Read Register Instructions

5.2.1 Read Core Address Register (CAR)

IOX 500 % (CAR) → A

This instruction is included for maintenance purposes to check for correct wiring of the channel and also to check that the core address register is counting correctly.

After a read parity transfer the register will be incremented.

5.2.2 Read Sector Counter (SECT)

IOX 502 % (SECT) ----> A

This instruction reads the instantaneous state of the sector counter into the accumulator. Only bits 0-4 of the accumulator are relevant, the rest of the bits have to be masked out. The content of the sector counter defines the absolute rotational position of the disc selected, i. e. the absolute position of the heads.

5.2.3 Read Status Register (STR)

IOX 504 % (STR) ----> A

The status word gives information about the state of the disc controller and the selected disc unit. The status word contains the following information:

Bit	0	Ready for transfer, interrupt enabled
	1	Error interrupt enabled
	2	Device active
	3	Device finished
	4	Inclusive OR of errors (status bits 5-11)
	5	Write protect violate
	6	Time out
	7	Hardware error
	8	Address mismatch
	9	Parity error
	10	Compare error
	11	Missing read clocks
	12	Transfer complete
	13	Transfer on
	14	On cylinder
	15	Bit 15 loaded by previous control word

14 On Cylinder

Indicates that the heads are on the track selected by the previous transfer.

- 13 Transfer on
The specified block address has been entered and data is transferred between core and disc.
- 12 Transfer Complete
The desired number of words have been transferred and the word count register is zero.
- 11 Missing read clocks
Missing read clock in data field. Data on this sector are lost.
- 10 Compare Error
A mismatch between data compared from the disc and from the computer memory has been detected during a compare test.
- 9 Parity Error
A mismatch between the cyclic check word read from the disc and the one generated in the controller has been detected.
- 8 Address Mismatch
A seek for the specified block address after the correct track was found has failed.
- 7 Hardware Error
Abnormal hardware condition within the selected disc drive. If this condition exists when a transfer is initiated, the transfer will immediately be terminated.
- 6 Time Out
Hardware fault condition causing a disc hangup, i.e. the started transfer is not terminated. The controller will terminate any transfer lasting for more than 300 ms. This bit will also be set if the track address specified is non-existent. The time out condition will automate a Return to Zero seek command and the disc heads will finally come to rest at cylinder 0.

5 Write Protect Violate

The block address register (BAR) contains a protected address as specified by the protect switch register and the device operation code is write transfer.

4 Inclusive OR of Errors

If either of the status bits 5-11 are set this bit will be set.

5.3 Seek Instruction

IOX 506

After initiating the load Block Address Register and load Control Word with the desired unit number, this instruction may be used to position the unit on a wanted cylinder. Immediately after this instruction has been issued, a new unit may be selected and a new seek or transfer may be performed on this unit.

While a normal transfer is performed, it is prohibited to issue a new seek instruction.

To check if the selected unit is correctly positioned - an IOX SEEK instruction should be issued followed by an IOX RST (Read Status). With a correctly positioned disc unit, the on cylinder signal (Status bit 14) will be true.

5.4 Data Transfer5.4.1 Starting a Transfer

Before a transfer may be started the status register has to be read to check that the selected unit is ready (Status bit 14). If this is true the transfer may be started by loading the desired control word including bit 2 set (activate device).

5.4.2 Completion of a Transfer

After a transfer has been started there are two ways of detecting the completion.

- 1) By reading status and performing a BSKP ZERO on bit 2 (device active).
- 2) By sensing interrupt.

After a completion has been detected, the success of the transfer may be checked by reading status and check bit 4 (Inclusive OR of errors). If this bit is zero the transfer has been good.

5.4.3

Interrupt

The disc interrupt level is 11 and the ident number for the first disc system is 1.

6

WRITE PROTECT

On a Hawk disc unit, every cartridge (removable or fixed) may be write protected, independent of all other cartridges .

On the front of the disc unit there are two protect buttons labeled

- "write protect cartridge" and
- "write protect fixed".

If one of these buttons is pushed, the light will go on and the corresponding cartridge will be protected.

If the button is pushed again, the light will go off and the cartridge will be unprotected.

The protect bit in the status word does not work with Hawk disc units!



NORSK DATA A.S.
Lørenvæn 57 - Postboks 163, Økern
OSLO 1

COMMENT AND EVALUATION SHEET

ND-11.008.01

Cartridge Disc System for NORD-10
Computer - Programming Specifications

In order for this manual to develop to the point where it best suits your needs, we must have your comments, corrections, suggestions for additions, etc. Please write down your comments on this pre-addressed form and post it. Please be specific wherever possible.

FROM:
